

# BEACH HAVEN Business District Design Guidelines



Photo credit: Ann Coen Photography



# Beach Haven Business District Design Guidelines

February 11, 2024



## Borough of Beach Haven

### **Design Guideline Committee:**

Sherry Mason, Borough Manager

Jeanette Lloyd

Nicole Baxter

Jaime Baumiller

Molly Fallon



**JSD / The Design Group**

Architectural and Planning Consultants

Phone: (802) 496-2166

Jeff Schoellkopf, AIA, Principal



# Contents

<b>1. Introduction</b>	<b>1</b>
Use of the Guidelines	2
Applicability	3
Town Review Process	4
<b>2. Historic Contexts</b>	<b>5</b>
<b>3. Building Character</b>	<b>6</b>
Building Compatibility	7
<b>4. Building Mass</b>	<b>11</b>
Setback	11
Height	13
Width	13
<b>5. Roofs</b>	<b>15</b>
Roof Design	15
Dormers	18
Cupolas	18
Roofing Materials	18
<b>6. Facades</b>	<b>19</b>
General Building Facades	19
Side and Rear Facades	20
Foundations	20
Siding Materials and Trim	21
Openings and Entries	23
Porches	24
Covered Walkways	24
Decks and Exterior Stairs	25
Buildings on Corners	26
Awnings	27
<b>7. Streetscape</b>	<b>28</b>
<b>8. Landscaping</b>	<b>29</b>
<b>9. Flood Elevation</b>	<b>30</b>
<b>10. Accessibility</b>	<b>31</b>
<b>11. Parking</b>	<b>32</b>
<b>12. Lighting</b>	<b>33</b>
<b>13. Fencing and Screening</b>	<b>34</b>
<b>14. Service and Loading</b>	<b>39</b>
<b>15. Signage</b>	<b>40</b>

# 1. Introduction



Bay Ave, between Engleside Ave. and Centre St.

The town of Beach Haven is a coastal community located in Southern Long Beach Island, which caters to its year-round residents, property owners, business community, as well as to its summer vacationers. Beach Haven is known as a resort town because of its emphasis on being a family-oriented vacation destination and is unique because of its scale, charm, location, character, and special beaches.

## Goals:

- Develop and enhance the character of the downtown.
- Provide greater architectural continuity and cohesiveness.
- Encourage a commercially vibrant core in the district. Generally maintaining human scale, density, massing, and existing height limits to continue to help develop an attractive high quality coastal residential resort community.
- Encourage that adjacent buildings work together to reinforce the character of the business district as a vital and lively place abundant with diversity of businesses and services.
- Provide for improved bicycle and pedestrian safety.

At the core of Beach Haven, is its Business District stretching along Long Beach Boulevard (Bay Avenue) from 12th Street to Pearl Street. The primary Business District provides neighborhood businesses including shops, stores, restaurants, arcades, amusement parks, pharmacies, and municipal services. In addition to these functions, they provide much-needed gathering places for residents and visitors and are key elements to the identity and character of Beach Haven as a whole.

Property within the downtown business district provides the core function and “physical backdrop” for public life. The businesses work together to provide an integral part of the community’s experience as a place where people want to stroll, shop, and interact with their friends, family, and neighbors.

Through the development and use of these guidelines, Beach Haven hopes to encourage and inspire property owners and developers to continue to develop an improved character in this district. These may also be applied during Architectural Advisory Committee (AAC) review to all business and multiuse properties in all zoning districts.

A critical ingredient in any development and redevelopment process is the presence of strong design characteristics. Successful revitalization projects in towns that have created vibrant downtown areas have included four key elements:

- Community consensus and commitment
- Streetscape amenities
- Design guidelines
- Effective zoning and review process

We envision a town that is a welcoming and attractive community that more than satisfies the needs of the various stakeholders in Beach Haven. That vision encompasses our clean and safe beaches and bay, a warm and inviting business district, our charming historic neighborhoods, and well-maintained facilities, as well as our outstanding municipal services.

### Use of the Guidelines

The intent is to implement these guidelines to help guide quality, encourage compatibility, and improve town identity, while allowing for creativity and individual commercial presence. The design guidelines are intended to be flexible and allow for creative design that are consistent with the overall goal to improve the business district of Beach Haven. This has been developed in order to provide property owners and developers with guidelines that will support an improved common vision for the borough. All references are advisory and use the terms “encourage”, “discourage”, “should”, and “should not”.

Reference photos and illustrations shown in this document exemplify the concepts described by the guidelines. The examples shown throughout this guideline manual are not the only acceptable solutions.

These Design Guidelines are intended to provide direction for business owners and potential applicants coming before AAC on the kind of alterations that the members deem appropriate. The Guidelines are also designed to help AAC make consistent and informed decisions about what is and is not appropriate. But as their name suggests, the Guidelines are intended as guides, not hard and fast rules. Each application before AAC will be considered on a case-by-case basis. The Guidelines will be a starting point, but not necessarily an ending point, in the process.



511 N Bay Ave.



309 Centre St.



308 Centre St.

Examples of mixed-use, renovated buildings



Mixed-use, 1 S Bay Ave. at Centre St.



Renovated boutique, 1103 N Bay Ave.



Renovated restaurant, 1106 N Bay Ave. at Ninth St.

This presentation is a guide for owners in the Beach Haven Business District. Whether the project involves improvements, renovations or new construction, the principals here will help to design appropriate work. The core of these guidelines explains the principles of appropriate treatment. Photographs illustrating what to do and what not to do for different buildings elements are also included. Visual compatibility factors are presented to help new construction fit into the business streetscapes. These are examples of successful projects throughout the business district.

Everyone can use and learn from these guidelines. Business owners should see them as a planning tool. AAC will depend on them to clarify their discussion with applicants.

### **Applicability**

This design guideline manual applies to the Business District Zone, and all other businesses throughout the zoning districts of Beach Haven. The guidelines address the site design and use, architectural design, use size, bulk, scale and signage, as well as landscape design. The guidelines apply to all construction, unless specifically excluded, including new and rehabilitated buildings.

The design guidelines are intended to guide property owners, builders, planners, engineers and architects in designing projects that will be compatible with, and will improve the quality. If the project is unable to meet the recommendations of these guidelines due to unique conditions, it should still meet the intent of the guidelines in those areas that are not affected by those unusual conditions.



## Town Review Process

### ARCHITECTURAL ADVISORY COMMITTEE

The Architectural Advisory Committee (AAC) is not an approving authority. The AAC provides recommendations and guidance to the Beach Haven Council and the Land Use Board (LUB) for new development and redevelopment applications primarily in the Marine Commercial and Business Districts. The committee consists of members experienced in building, architectural design, and engineering.

#### Roles and Responsibilities of AAC Committee Members

1. Understanding of the Master Plan and Zoning
2. Understanding of Redevelopment/Rehabilitation process

#### Procedures for Initiating the Review.

- Prior to a formal review, the applicant shall meet with the Beach Haven Zoning Department. Once submitted to the site plan process, the application will follow the review process as defined by Borough Code 167-3 Site Plan Review. A meeting shall be scheduled with the AAC and applicant. The AAC shall be provided with the opportunity to comment on all site plans as part of the AAC review process. Such comments and recommendations will be forwarded to the Borough Engineer, Borough Manager, and Town Council.
- Prior to consideration for a Redevelopment Plan, applicants shall meet with the Town Council. A meeting shall be scheduled with the AAC and applicant. The AAC shall be provided with the opportunity to comment on all site plans as part of the AAC review process. Such comments and recommendations will be forwarded to the Borough Engineer, Borough Manager, and Town Council.

### CHECKLIST FOR SUBMISSION OF AAC APPLICATION

1. Site and landscape plan, with site lighting
2. Architectural drawings of all floor elevations
3. Survey of lot and block which shows grade and flood zone information
4. Written narrative describing scope of work
5. Material description checklist: siding, roofing, windows, doors, exterior trim, paint colors.
6. Electronic and paper copies (3), (11x17) of all of the above

## 2. Historic Context



Beach Ave. at Centre St.



Bay Ave. at Centre St. and Dock Rd.



Third St. and Bay Ave.

Beach Haven was opened as a coastal resort in 1874. Founded mostly by Philadelphia railroad aristocracy and local Quaker developers. By 1900 it was beginning to attract vacationers from all over the East. They sailed over but mostly arrived by train after 1886; and stayed in the town's magnificent hotels. Beach Avenue, not Bay Avenue, was the main street in town. It was lined with small meat and grocery stores, a pharmacy, and ice cream parlors.

An auto bridge was opened in 1914, followed by a boom in real estate following the First World War. The promoters were beginning to refer to Bay Avenue as the main street through the heart of Beach Haven. The big hotels had lost their panache as more and more of their guests were building summer cottages. Bay Avenue was soon becoming the business district. By the 1920s, the town had entered the modern age. So was born a vital and connected business district which we proudly utilize today.

The approach that best suits the expressed interests of residents, businesses, and other property owners is to think of future development and redevelopment as rooted in local tradition and historical context but expressing a new generation. To maintain the best of local character while encouraging a freshness to evolve.

These guidelines encourage the use of traditional form and materials in new and creative ways. Many of the notable buildings in the area were built with gable roofs, shingle siding, and double hung windows. But, the most notable have the unique bay window, odd shaped porch, the unusual tower, the special trellis, fence, garden, or courtyard. These are the kinds of things and places we want to encourage.

# 3. Building Character

The core architectural character of the business district can best be described as “Seaside Cottage” of a stick and shingle style. Although some buildings with elements of Victorian design, the historic buildings in this area are known to be elegant in their simplicity.

To retain this uniqueness and to create a sense of place, these buildings should serve as a character reference for renovation and redevelopment of the business districts.

The common characteristics of this style are still apparent today in Beach Haven. These buildings are simple geometric forms of mostly two stories as found in the stores of Bay Village and at Schooner’s Wharf. While building massing is often asymmetrical, windows and doors are most often arranged in a somewhat ordered pattern creating a balanced façade.

From the 1930s to the 1950s, some of the buildings in the business district were built with flat roofs with various parapets. Others have pitched roofs with dormers, towers, and gable ends that grace the rooflines adding to their unique charm. Both types are acceptable but the cornice details and broken up massing of flat roofed buildings is particularly important.

While building massing is often asymmetrical, windows and doors are most often arranged in a somewhat ordered symmetrical pattern, creating balanced façades. The windows are often tall, rising to the ceiling line, and transoms are occasionally used to maximize air circulation.

In the residential district porches add character to many of the homes. These may be helpful in the business zones to make the streetscape more pedestrian friendly. They are usually supported with large, white or natural wood columns, either round or square. The columns are connected with rounded railings and square pickets. Locally produced lumber and cedar shingles were materials most often used for framing and exterior shingles. The dominance of shingles and clapboard siding reflects both the tastes of the era and the carpentry of the builders who built the homes and stores.

Buildings of various forms, types and characteristics are allowable under the more specific guidelines which follow.

## **Common and encouraged design elements and architectural characteristics associated with the traditional styles include the following:**

- Simple building masses with gable or hip roofs of varying shapes and pitches, gable, shed or hip dormers
- Generous porches with large-scale columns on first and occasionally second floors
- Clapboard and shingle siding and brick chimneys and foundation walls
- Board and batten on upper floor gable ends
- Large plate-glass storefront windows
- Simple railings, trellises, gates and fences mostly weathered wood or white painted
- Fabric or metal storm shutters and window awnings
- Wood Posts and Columns
- Articulated relief detailing that emphasizes space, shadow and depth
- Frieze boards, gable brackets and exposed rafter tails
- Corner articulation with towers, turrets, corner bays or wrap-around porches



Bay Ave. at Second St. looking east

### Building Compatibility

The size, bulk and scale of new buildings should be generally compatible and in scale with adjacent structures in the surrounding neighborhood. However, some variety is encouraged.

Where the proposed structure is significantly taller or larger than existing adjacent structures, one or more of the following methods should be used to make the structure compatible:

- Roof types that minimize building mass at the perimeter
- Architectural treatments such as varying building materials, window size and color
- Large building facades broken into smaller units



Bay Ave. between Sixth St. and Fifth St. looking east

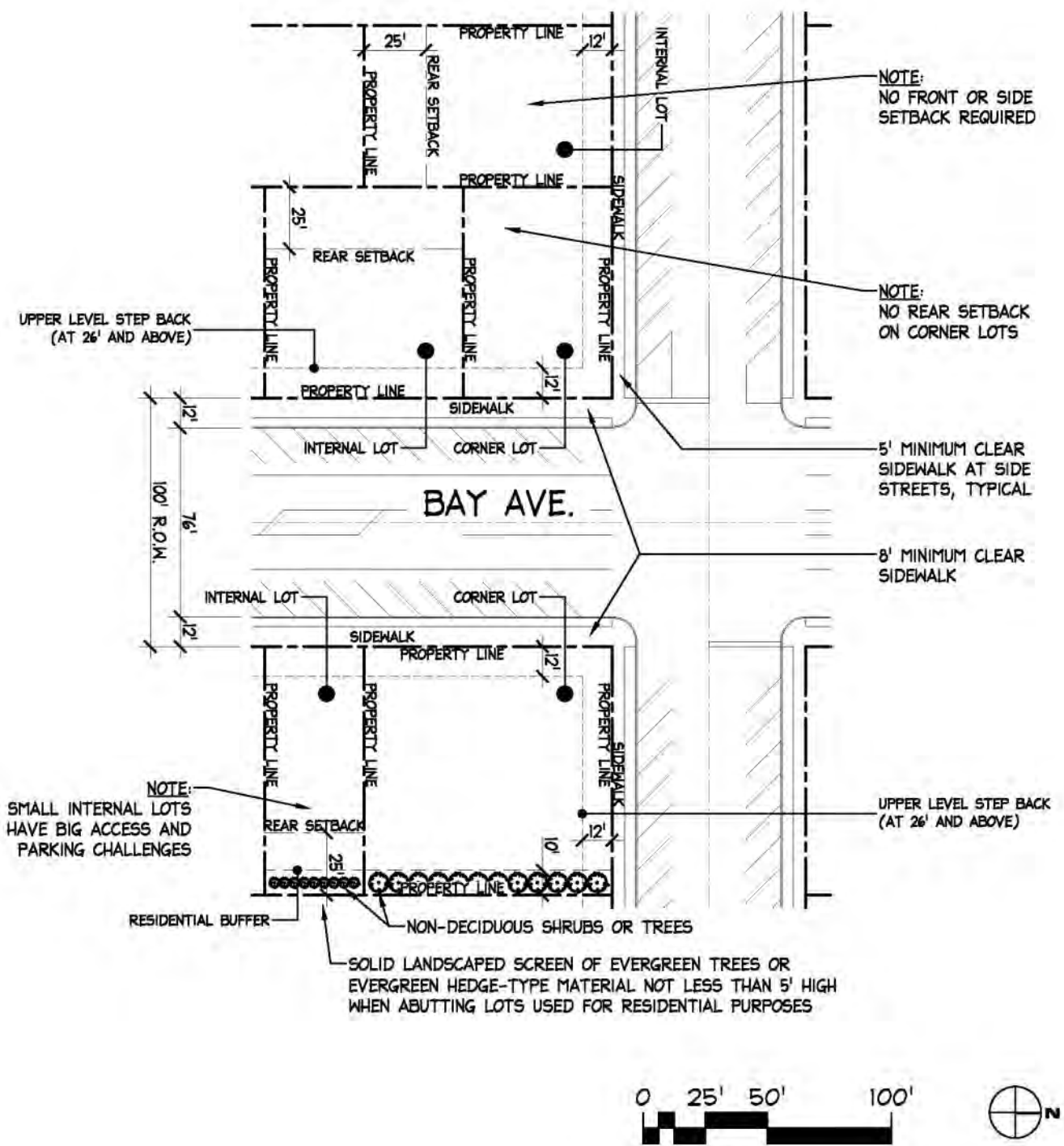

TYPICAL PROPERTY, ROAD, AND SIDEWALK DIMENSIONS, SHOWING TYPICAL STREET PARKING, ZONING REQUIRED SETBACKS, RECOMMENDED UPPER LEVEL STEP BACKS, AND REQUIRED BUFFERS.

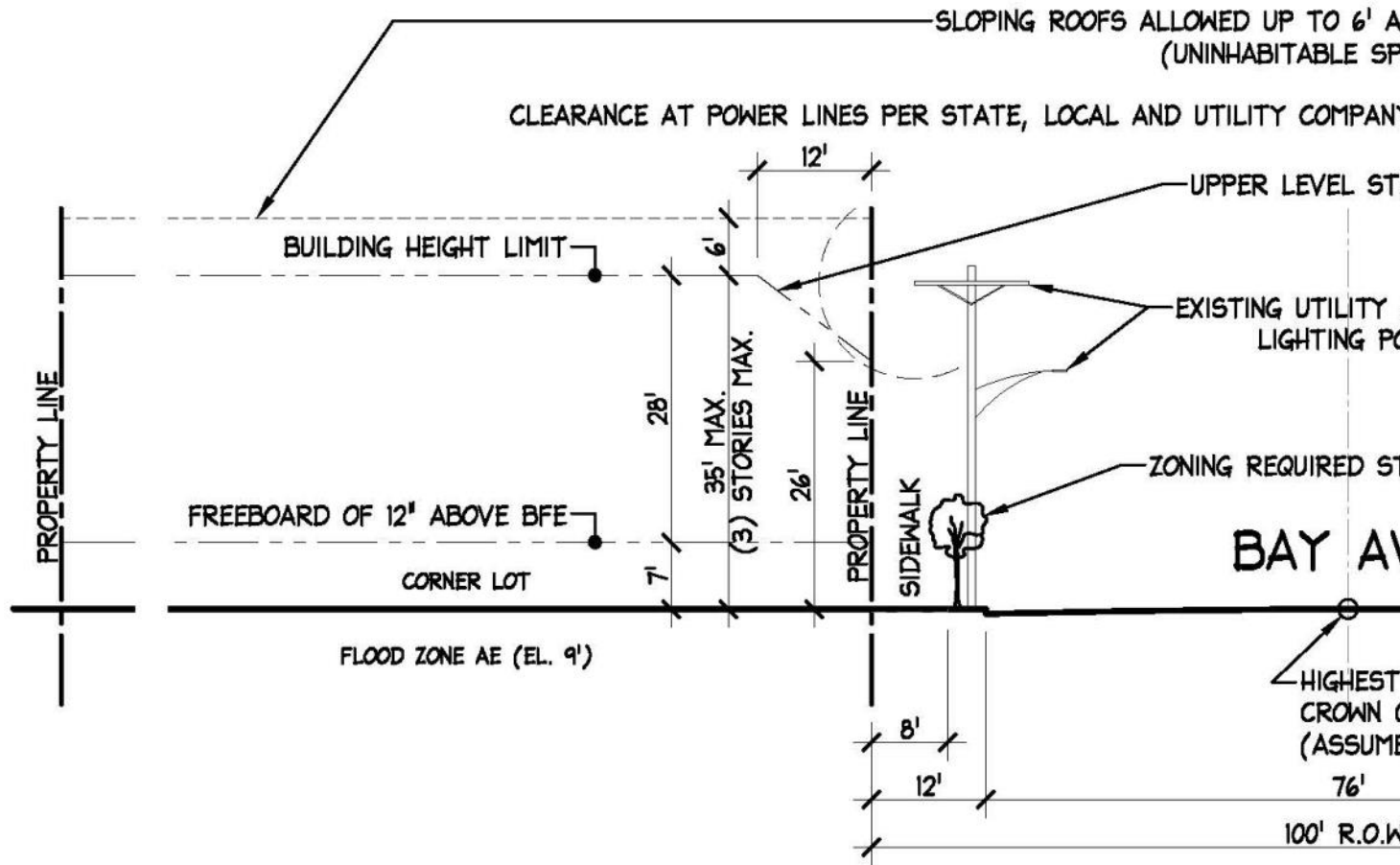

To provide a comfortable and interesting pedestrian experience, the ratio of building height to the distance between buildings must relate to the human scale. The Business District is characterized by a broad and open highway and mostly 2-story buildings.

SOLID LANDSCAPED SCREEN OF EVERGREEN TREES OR EVERGREEN HEDGE-TYPE MATERIAL NOT LESS THAN 5' HIGH WHEN ABUTTING LOTS USED FOR RESIDENTIAL PURPOSES

CHIMNEYS MAY BE ERECTED UP TO 2' ABOVE BUILDING HEIGHT LIMIT

ABOVE BUILDING HEIGHT LIMIT (FACE ONLY)

BY REGULATIONS, TYPICAL

EP BACK

/ STREET  
OLE

TREET TREE

VE.

POINT OF THE  
OF THE ROAD  
ED EL. 3')

l.

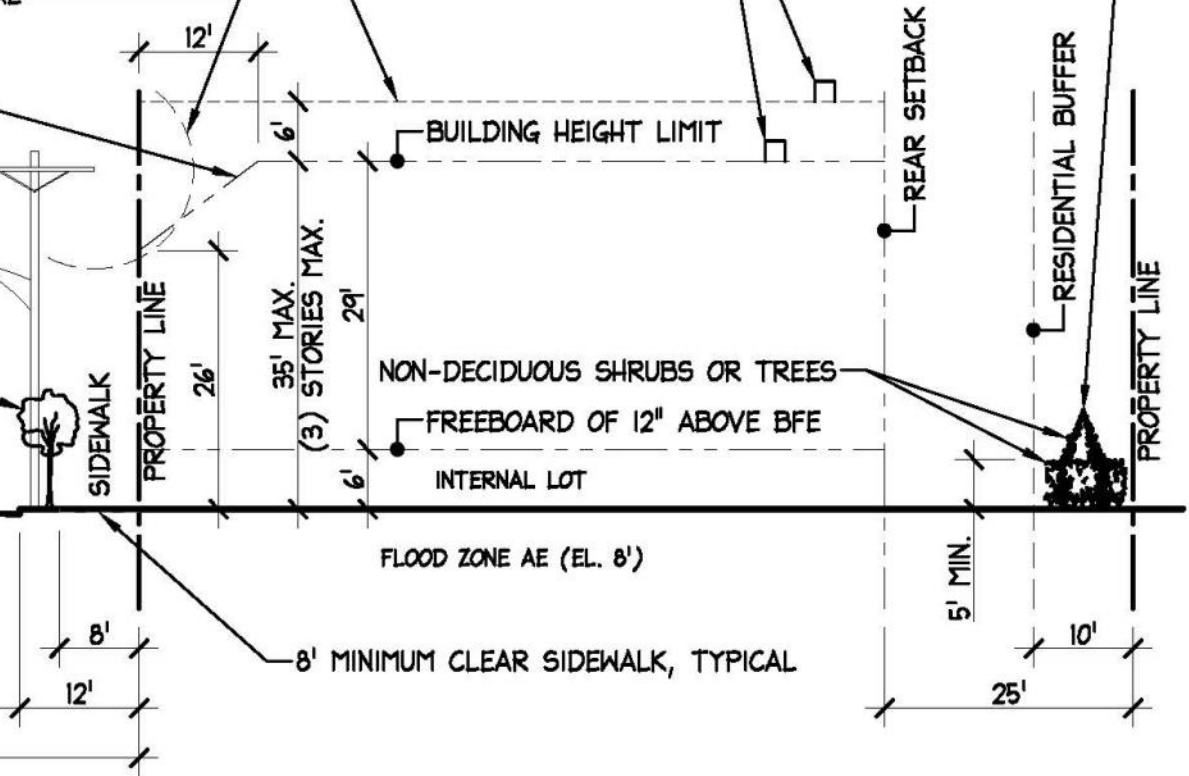

# 4. Building Mass

Generally, buildings shall be of basic traditional forms, which may be composed as an additive collection of elements. The space of porches and entries may be of additive elements or subtractive space

New buildings may be larger than existing smaller and single story structures. However, the height, width and roof design guidelines referenced in the Manual are intended to break down the scale of such larger buildings. Building mass shall be articulated by varying building volume, roof heights and roof types in buildings 40 feet or longer.

Single-story flat roofed buildings are discouraged unless designed with a varied and very interesting parapet. Two-story buildings are encouraged. Three stories allowed with setbacks applied and provisions made to maintain the scale of the streetscape.

## Setback

All new buildings and additions must adhere to the setback requirements as defined in the Borough of Beach Haven Zoning Chapter 212.

### Encouraged

- Generally building setback to allow wide sidewalks and porches along the street.
- All three story building to have the third floor set back an additional 12' to the face of the building or upper level deck.
- Rooftop decks should be set back and not visible from the street view, the extent of which depends on the height of adjacent buildings, and views from public vantage points surrounding the building.
- Tower elements and roof dormers are encouraged, adding up to no more than 25% of the building frontage.

### Discouraged:

- Three story buildings straight up at the front property lines.
- Rooftop decks visible from surrounding streets or public sidewalks (street views.)



# EXAMPLES OF 2 STORY FAÇADE SECTIONS

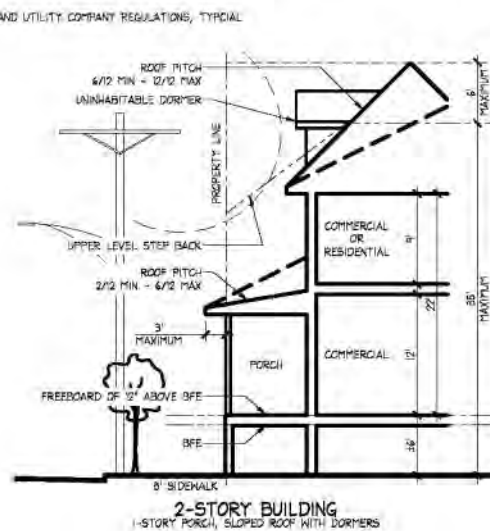
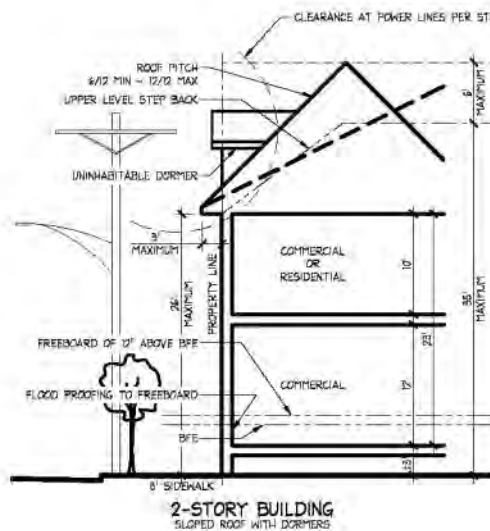
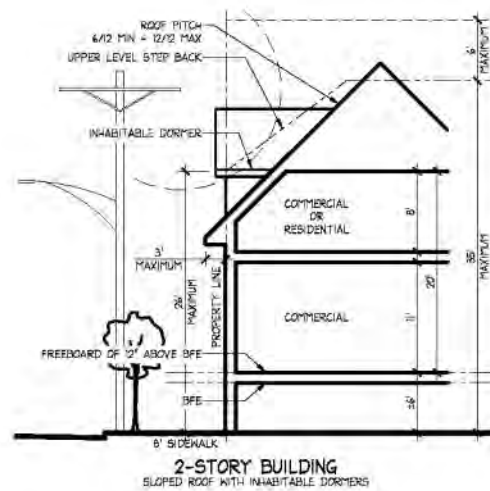
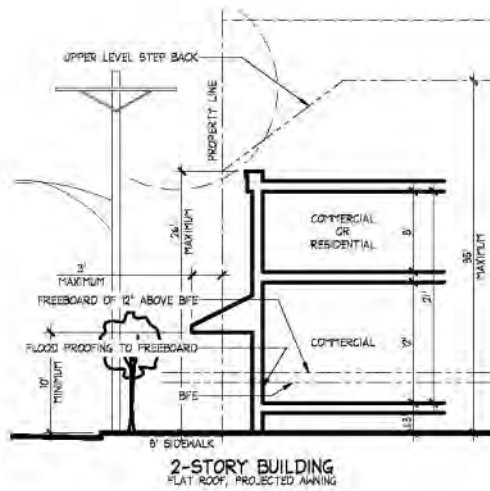
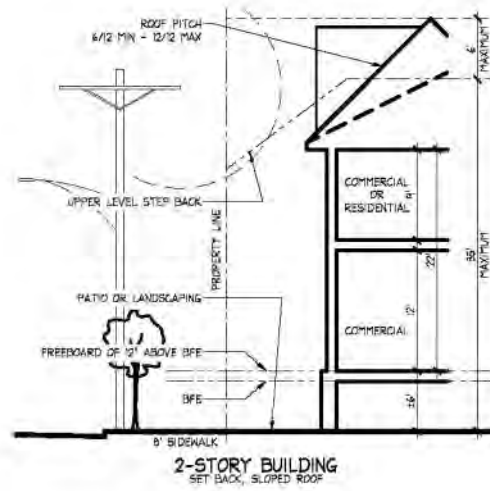
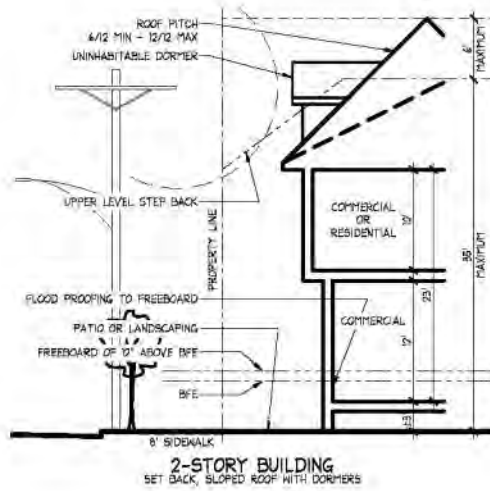

## Height

The relationship of the building height and width to the street defines the character of the downtown. Appropriate building massing contributes to the livability and quality of the downtown experience. It is desirable that buildings within the business districts have a similarity of height, with mostly two stories along the property line.

- Buildings are allowed to be constructed to the height permitted in the district. Allowable maximum height is 35' with a max. of three stories.
- HVAC equipment and generators (which shall be attractively well screened) shall not be allowed to exceed height limitations.

.

## Width

The original downtown building lots were typically 30 to 40 feet wide. Although many buildings today occupy more than one lot, the dominant building lot pattern remains. New development should respect this characteristic rhythm.

Building articulation is the key to creating appropriate scale, an interesting pedestrian environment and architectural vitality. Large, monolithic buildings degrade the character and atmosphere of downtown.

Encouraged:

- New construction on two or more lots or lots longer than 100' are encouraged to repeat traditional building widths by maintaining a similar division of the façade to maintain this progression.
- To ensure that new buildings are compatible with the existing character and scale of the district, such buildings should be organized into visible building increments of no more than 40' in width.
- Buildings that occupy more than 40' of frontage should be designed to appear as several smaller but related parts of a larger structure.

Discouraged:

- Flat front façades longer than 40 feet without interruptions by a break in massing, setback, porch, or large bay.

# EXAMPLES OF 3 STORY FAÇADE SECTIONS WITH TOP FLOOR SETBACK

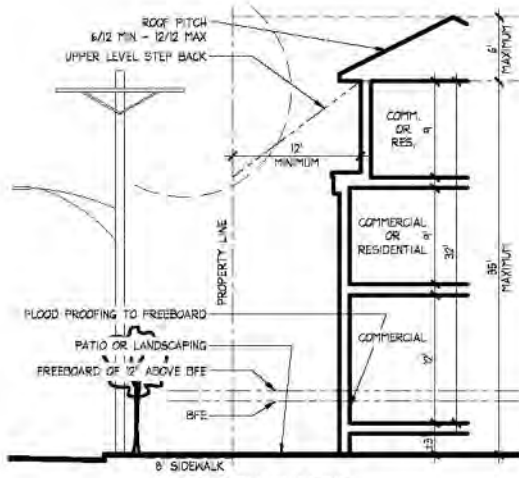

**3-STORY BUILDING**  
SET BACK, SLOPED ROOF, THIRD FLOOR STEP BACK

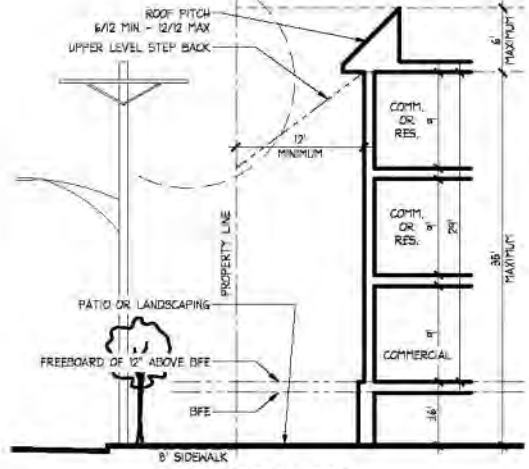

**3-STORY BUILDING**  
SET BACK, MANSARD ROOF EDGE

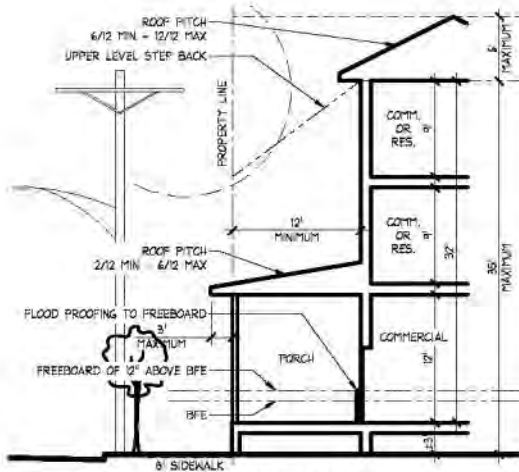

**3-STORY BUILDING**  
1-STORY PORCH, SLOPED ROOF, SECOND AND THIRD FLOOR STEP BACK

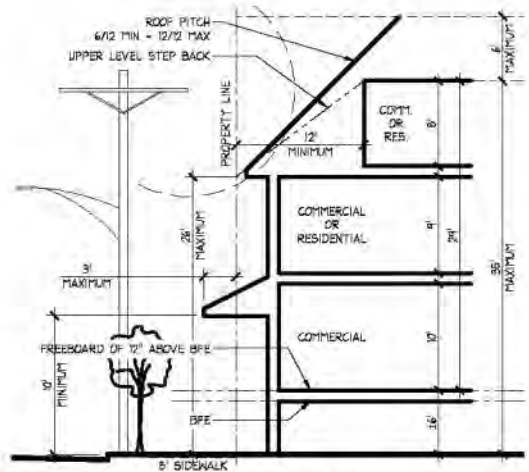

**3-STORY BUILDING**  
SLOPED ROOF, PROJECTED AWNING, THIRD FLOOR STEP BACK

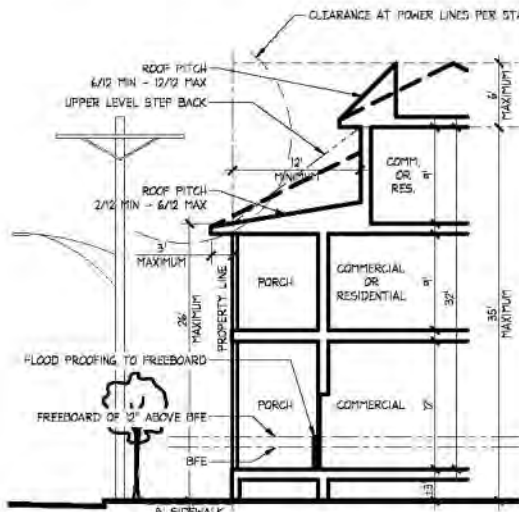

**3-STORY BUILDING**  
2-STORY PORCH, MANSARD ROOF EDGE, THIRD FLOOR STEP BACK

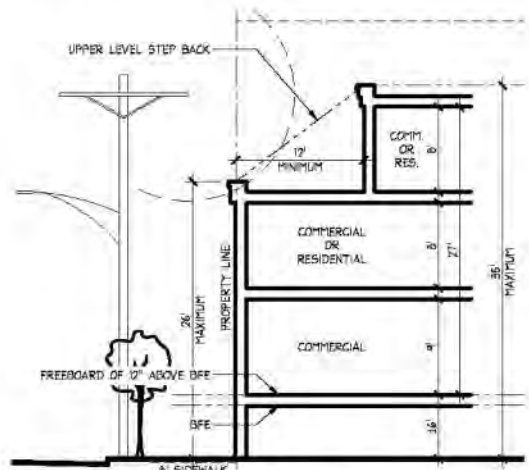

**3-STORY BUILDING**  
FLAT ROOF, PARAPET WITH CORNICE, THIRD FLOOR STEP BACK

# 5. Roofs

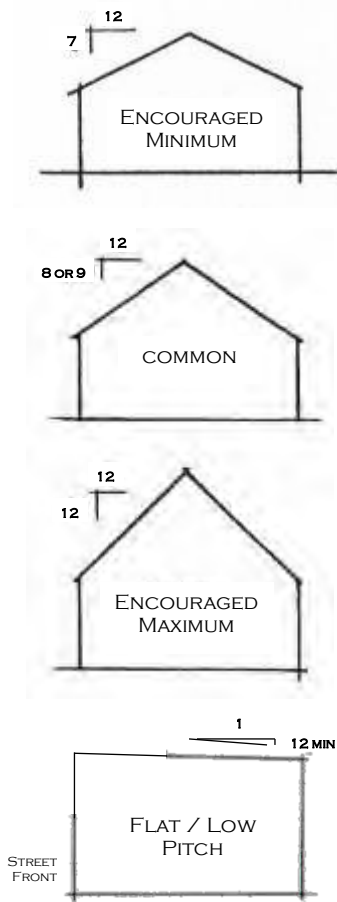

ROOF PITCH GENERAL DIAGRAMS



Britz's Bar - Corner of Centre and Bay Ave.  
presently the Marlin Bar and Restaurant

## Roof Design

Roofs are a defining element of a community's history and character. The most common types of roofs in downtown Beach Haven are gable, hip and flat.

### Encouraged:

- Roofs throughout downtown should be simple and basic in mass and form.
- Roofs may be gabled, hipped, flat/low pitched (up to 1/12) or a combination of these.
- Building with frontage that exceeds 40 feet should incorporate changes in roof form or type, which serves to reinforce the expression of the traditional building increment.
- Roof-mounted mechanical equipment shall be screened from view by attractive lattice, railings or roof forms that are designed as an integral part of the building architecture.
- New design should respect the alignment of neighboring building cornices or roof lines and other horizontal elements.
- Main roofs of buildings if pitched should be 7/12 min and 12/12 max. Porch and shed roofs should be 2/12 Min. and 8/12 max; Provide cornices and detail at flat roof parapets.
- Architectural enhancements including dormers and decorative trim.
- Exposed rafter ends and brackets (or tabs) at overhangs, soffits and eaves.
- Gable end and eave brackets.

### Discouraged:

- Flat faced parapets
- Long, unbroken mansard roofs
- Plainly detailed flat roofs
- Rooftop decks visible from surrounding streets or public sidewalks (street views.)

## Flat Roofs

Flat roofs are acceptable if built within the traditional character. This might include a projecting cornice, layered parapet elements (3-D, not flat), a three-dimensional façade (bay windows) and limited length of façade without break (40 feet max on street front).



Schooner's Wharf - Ninth St. and Bay Ave. looking west



Second Street at 117 N Bay Ave.



Taylor Ave. at 823 N Bay Ave.

# BASIC ROOF FORMS

## PITCHED ROOFS

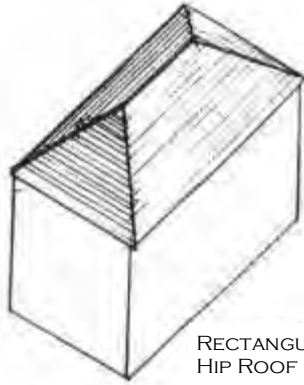

RECTANGULAR HIP ROOF

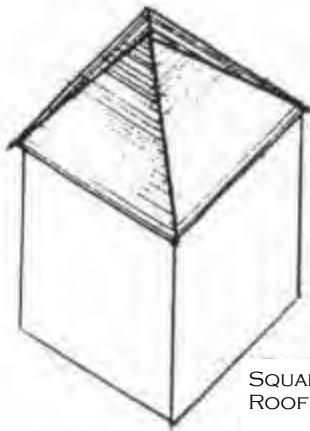

SQUARE HIP ROOF

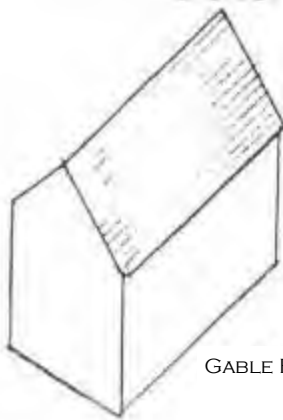

GABLE ROOF

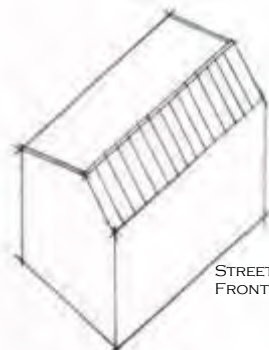

STREET FRONT

COMBINATION ROOF

## FLAT ROOFS

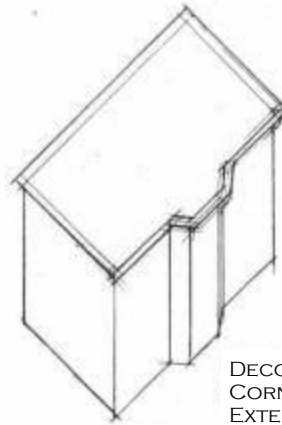

DECORATIVE CORNICE W/ BAY EXTENSION (S)

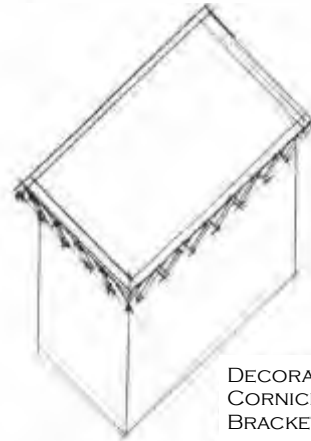

DECORATIVE CORNICE W/ BRACKETS

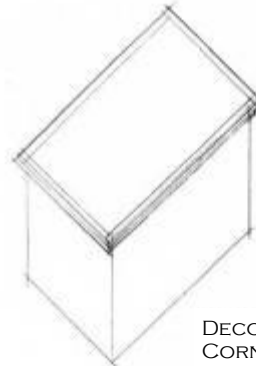

DECORATIVE CORNICE

## Dormers

Traditional dormers such as shed, gable and hip are encouraged. They should be modest in proportion to the overall roof shape.

## Cupolas & Widow's Walks

Cupolas and widow's walks not larger than 8 feet by 8 feet may extend 4-1/2' above the height limit. One allowed per 50' of frontage.

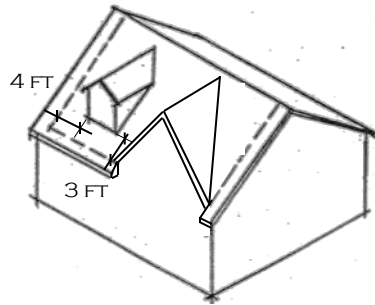

SMALL DORMERS SHOULD BE SET BACK AT LEAST 4 FEET FROM EITHER END OF THE BUILDING AND 3 FEET FROM THE FRONT EAVE. LARGE DORMERS MAY BE FLUSH WITH THE BUILDING FAÇADE.

### BASIC DORMER FORMS

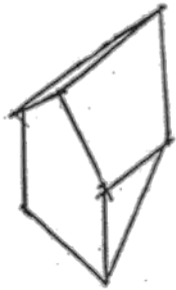

GABLE DORMER

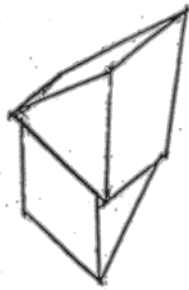

HIPPED DORMER

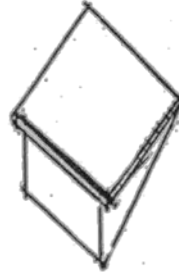

SHED DORMER

## Roofing Materials

Encouraged:

- Exposed roofing materials shall be asphalt and/or fiberglass, metal standing seam, slate, composite shingles or fire retardant treated wood shingles.
- Flat and low-pitched roofs should be light colored to be generally heat reflective, and may be bituminous, built up or single ply roofing.

# 6. Facades

## FACADES

EXAMPLES OF COMPLIANT STREET FRONT/STORE FRONT FACADES



2-STORY BUILDING WITH STREET LEVEL AND UPPER LEVEL COVERED PORCHES AND GABLE DORMERS



2-STORY FLAT ROOF BUILDING WITH BRACKETED PARAPET AND BAY WINDOW

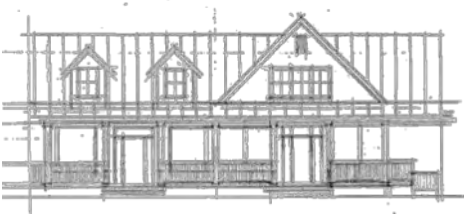

2-STORY BUILDING WITH 1-STORY STREET LEVEL PORCH AND 2ND FLOOR SPACES UNDER ROOF

The façade is literally the “face” of the building on the street. Proper detailing of walls, windows, doors and porches contributes to architectural quality, both in the rhythm of these openings and in the detailing of each opening itself. Windows act as eyes onto the street, contributing to street activity and improved safety. Existing business buildings in Beach Haven are diverse in period, style and materials.

## General Building Facades

Encouraged:

- Although architectural styles may vary from building to building, similar patterns of entries and storefronts are encouraged.
- Quality materials should be employed, especially on the ground floor. Special attention should be paid to window and entry trim detailing.
- One building entrance should be provided every 25 to 50 feet to encourage a high level of pedestrian activity to the street.
- Glass on storefronts should be transparent, and not covered with posters and signs.
- Individual shop or tenant spaces should be expressed on a building’s exterior through the rhythm of openings, walls and columns, as well as the careful use of color and materials.
- Professional buildings should provide window openings and detailed entrances that maintain pedestrian and visual interest along the sidewalk.
- Regularly spaced windows in the upper façade, with attention to rhythm and form.
- Porches either utilized as shared entries or glass enclosed as usable commercial space.
- Sidewalk areas or courtyards large enough for café seating . These need to define and allow a minimum of 8’ clear sidewalks for passing pedestrians and cyclists.
- Appropriately designed and detailed shed awnings and canopies above the first floor that provide shade and architectural interest.
- Recessed entry areas.

Discouraged:

- False windows and doors on first floor facades.
- Windows should not exceed 9 feet in height from the sidewalk without a transom, or 5 feet in width without a sidelight or dividing structural element.
- Front or side street walls without window or door openings.



## Side and Rear Facades

A building's character should be consistent throughout, especially where the building will be visible from publicly accessible areas such as streets, alleys or parking areas. Although details may be simplified, elements like finish materials and architectural details should be related on each building façade.

When a building abuts a side property line in the interior of the block, or when that building's side wall is likely to remain visible for an extended period of time, the building's exposed façade should reflect a design treatment consistent with the building's established street-front design. It is recognized that in case this is a fire wall, openings are not allowed and materials must be non-combustible. All exposed façades must be treated with materials allowed per section.



Buffer Zone -between residential and commercial

## Foundations

Exposed areas of foundations shall consist of one of the following materials:

- Red brick
- Concrete – cast with brick or block texture and can be painted
- Old style rustic block
- Lattice or screening shall be encouraged between pilings and at exposed crawl spaces
- Purged cinder block or concrete (with attractive landscaping)

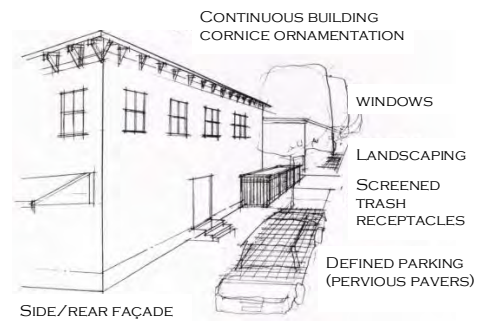
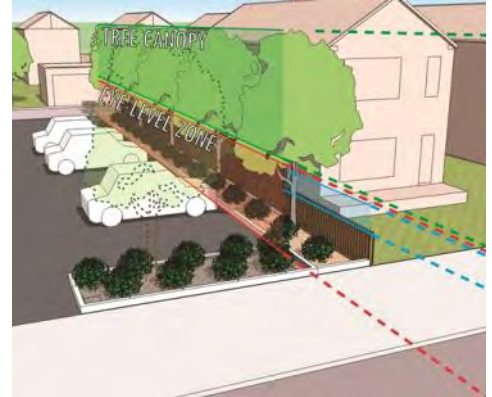

Buffer Zone -between residential and commercial

## Siding Materials & Trim

Façade standards are intended to preserve the traditional character of the downtown area. The choice of materials for building façades is critical to achieving this goal. The wood-shingled and clapboard exteriors of the early buildings add character to the often simple structures they adorn. The use of these patterns and textures will ensure that new construction is compatible with its older neighbors. Contemporary materials that provide a traditional appearance and are compatible with the objectives of these guidelines are allowed.

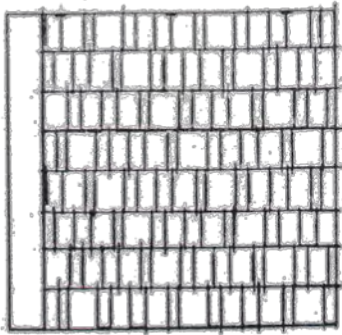

SHINGLE

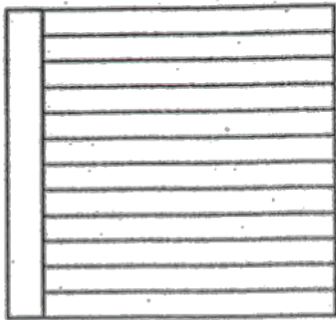

CLAPBOARD - 4"

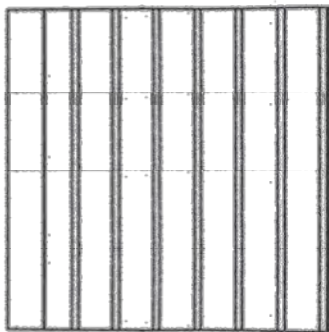

BOARD & BATTEN

### Encouraged

- Wood shingles and Horizontal clapboard.
- Board and batten in upper story and gable ends.
- Clapboard, shingles and board and batten may be painted, stained, natural wood, fiber cement or other composite materials as approved.
- Heavy gauge composite shingles.
- Red brick, with rowlock, stone, or concrete caps.
- Exterior Insulation Finished System (EIFS) for ornamental detailing and limited application that is above the second floor.

### Allowed

- Composite siding greater than 0.40" thick with rich texture.
- Parged block or painted concrete (on foundations and existing buildings only).

### Discouraged

- Aluminum and vinyl siding less than 0.40 inches thick.
- Texture 111 siding.
- Diagonal siding.
- Split face block.
- Parged block or plain concrete surfaces on street front facades above the foundation
- Rubble stone and formstone

# EXTERIOR WALL SIDING AND TRIM EXAMPLES

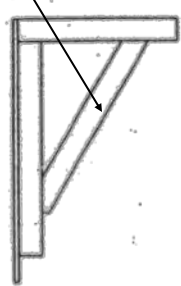
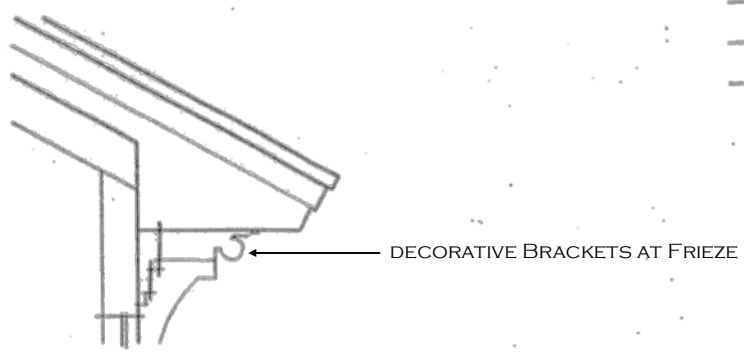
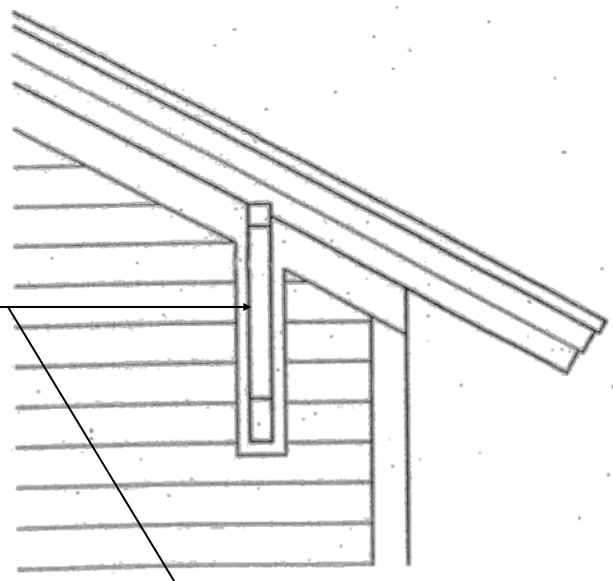
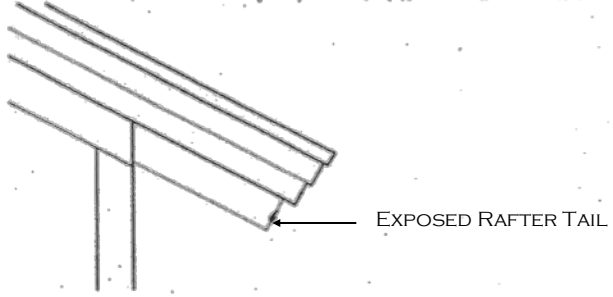
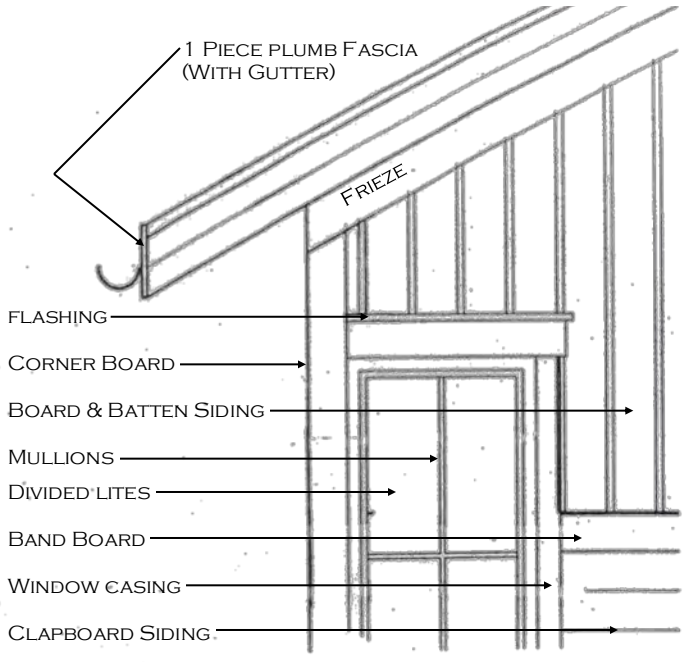
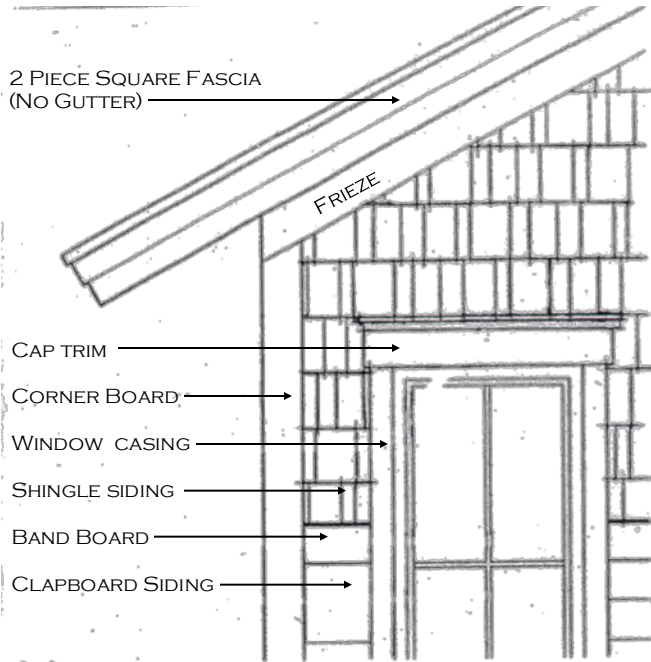



308 Centre St.



511 N Bay Ave.



901 N Bay Ave.

## Openings and Entries

### Windows:

Windows are encouraged to be of a generally traditional type (mostly rectangular or square). Unique bays and storefronts are encouraged. All windows shall be recessed a minimum of 2 inches from the face of the building to enhance shadow line around the opening.

Bay windows are desirable. Traditional elements range from simple sheds to round corner turrets. Divided lites are encouraged on all upper story windows.

### Encouraged

- First floor windows should be wood, fiberglass, or aluminum framed with rich trim surround. Max size of individual pane 7 feet high by 5 feet wide.
- Upper floor windows should be in a vertical or square pattern, with multiple divided lites.
- Transoms above windows are encouraged.

### Doors:

#### Primary Entries

Primary entries should be consistent with the chosen architectural style. Door materials shall be wood, glass, metal or fiberglass.

#### Encouraged:

- Doors that are flanked by columns, decorative fixtures or other details.
- Doors that are recessed within a larger arched or cased decorative opening.
- Doors that are covered by means of a portico projecting from or set into the building face.

#### Secondary Entries

Secondary entries should be enhanced with simple detailing so as to blend into the surrounding building façade. Where trash or storage areas are located in conjunction with service entries, such areas should be enclosed and screened by the use of design elements that are consistent with the particular style of building.

## Porches

Porches are a defining element of the downtown's seaside architecture. They provide relaxed and shady places where residents and pedestrians can comfortably relate to one another. This interaction creates a vital sense of community.

In the commercial districts, porches most often serve as common entry elements to public or multiple commercial uses, or they have been glassed in to take full advantage of commercial available space. In either case the employment of porches is encouraged but not required.

### Encouraged:

- Ground level porches should be a minimum of 8 feet deep.
- Porches should be supported by large square or round column posts, minimum of 6 inches by 6 inches, or 6 inches in diameter.
- railings should be traditional and must meet all zoning code requirements.
- Railings and columns should be wood, or other AAC approved composite materials.

### Discouraged

- Visual cantilevered decks or porches.

Front porches may be enclosed by screen, glass or other approved material, but shall maintain the character and form of a porch. Ground level porches shall not be filled with opaque walls higher than 2 feet above the floor. All other porch designs subject to review by the AAC.

Porches above the second floor should be integrated into the building mass, with porch posts provided at the outer edges for support.

## Covered Walkways

Covered walkways on the front of a commercial property allow for a wider walking area as well as a means to provide rain protection and shade on hot summer days.

### RECESSED PORCHES

PORCHES WHICH ARE "CARVED OUT" OF THE PRIMARY BUILDING MASS

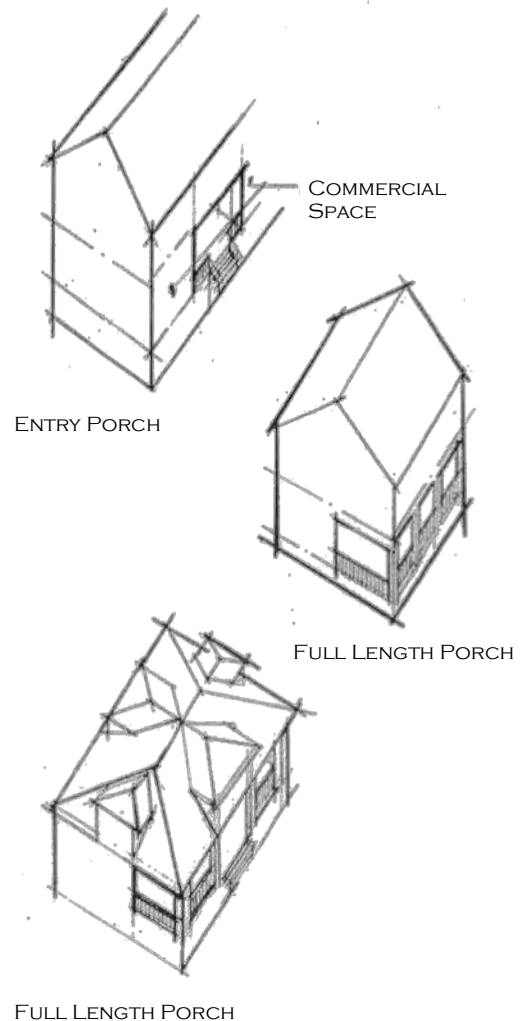

### ADDITIVE PORCHES

PORCHES WHICH ARE "ADDED TO" THE PRIMARY BUILDING MASS

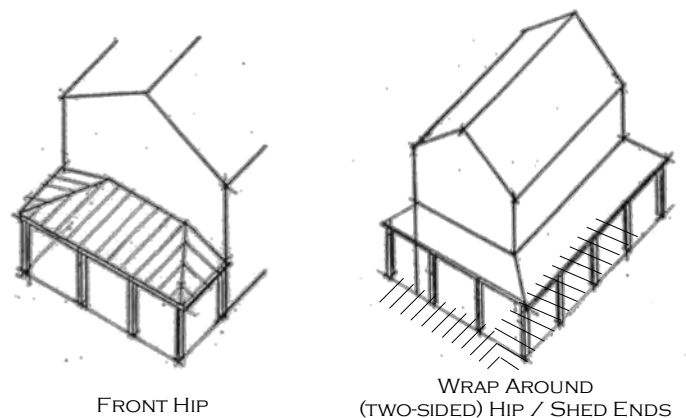

## Decks and Exterior Stairs

Decks and stairs should relate to the mass, scale, placement and detailing of a building and should be consistent with traditional architecture.

### Encouraged:

- Railings should be open in design.
- Materials such as flooring, edge bands, columns, trim, and railings may be painted, stained or naturally weathered, composite or wood.
- Stairs above the first floor in a rear yard or other permitted area should be integrated within the footprint of the main building as much as possible. Stairs should be sturdy in appearance and should be painted or stained.



1002 N Bay Ave.

### Discouraged

- Modern, glass, and cable railings.
- Rooftop decks that are visible from street view

### COLUMN TYPE EXAMPLES

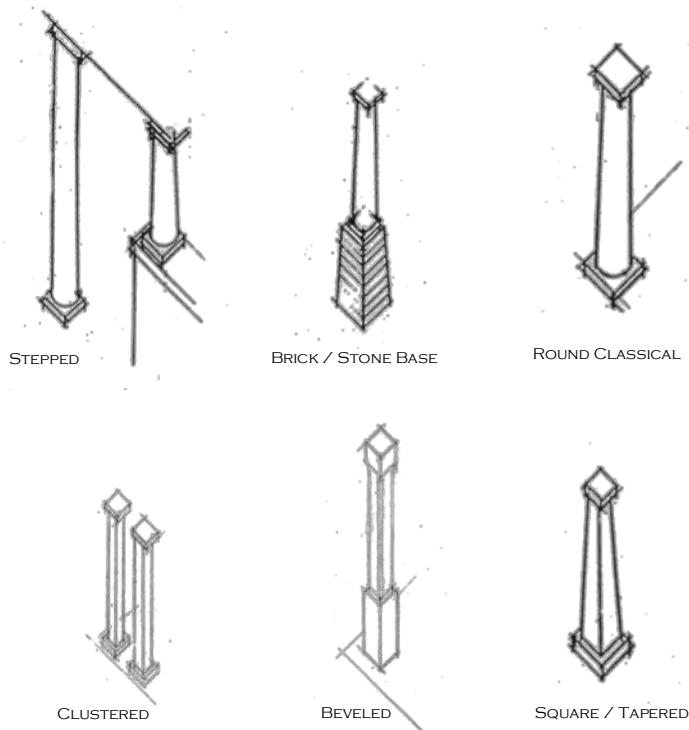

### TWO-STORY COLUMN EXAMPLES

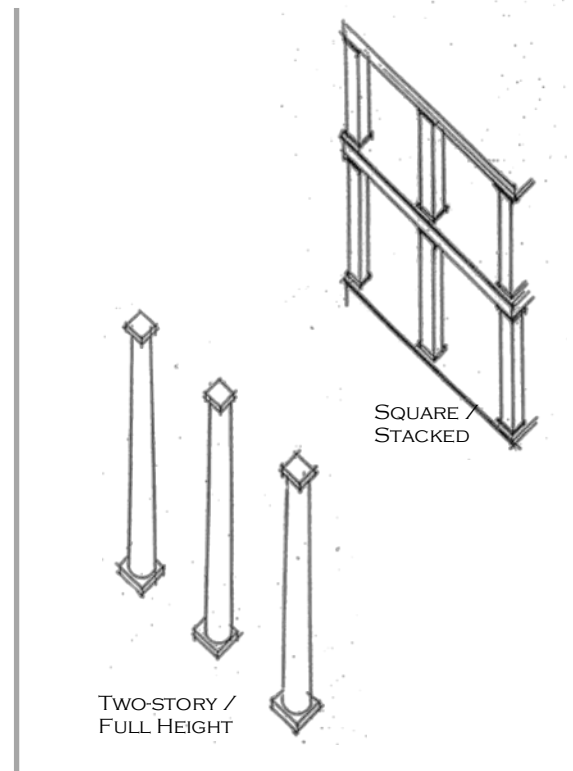

**RAILING TYPE EXAMPLES**

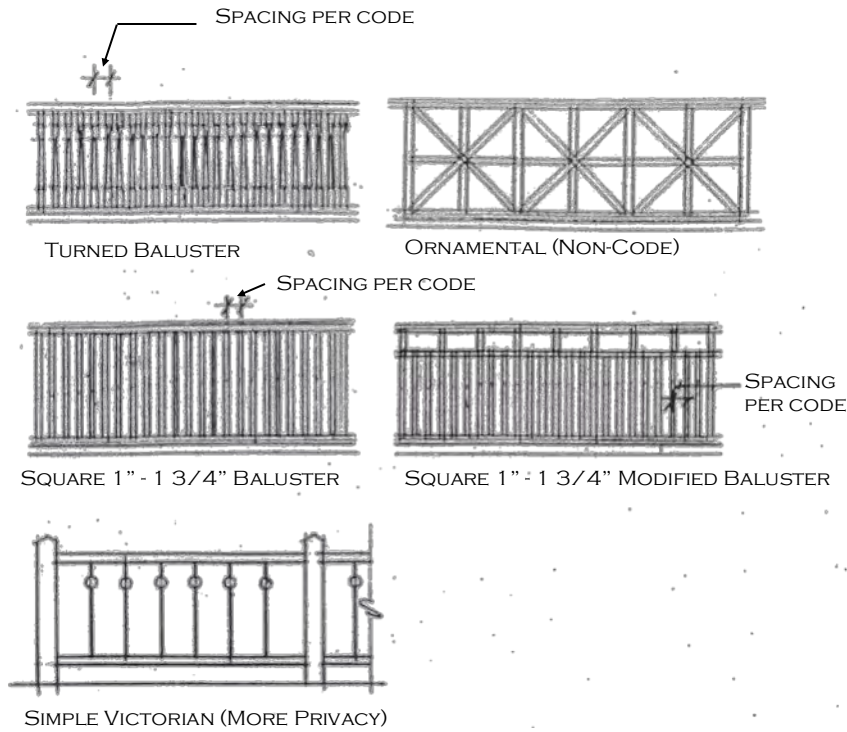

**DECKS AND BALCONIES**

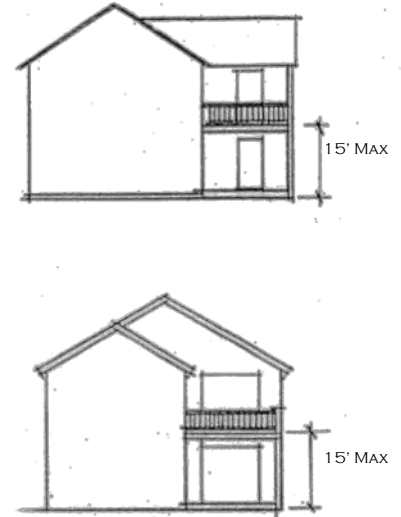

OPEN DECKS ANCHORED BY BUILDING MASSING

**Buildings on Corners**

Corner buildings should be distinctive, with rounded or angled corners to facilitate pedestrian flow. Façades should relate to the scale and massing of buildings on their respective streets.

**UNIQUE CORNERS**

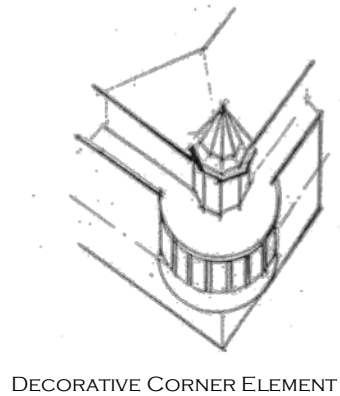
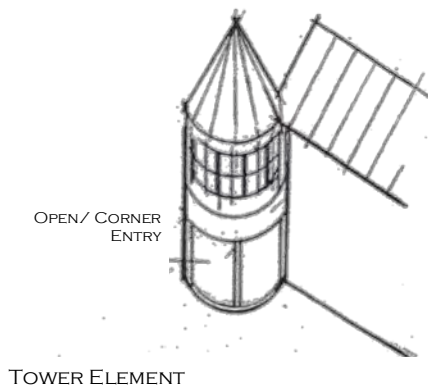

## Awnings

Awnings serve a functional purpose by protecting windows from intense direct sunlight and heat, and providing rain shelter at the sidewalk.

Encouraged:

- Awnings shall be of a durable, commercial grade fabric, aluminum or composite. Awning frames and supports should be of painted or coated metal or other non-corroding material.
- Awnings shall be shed style.
- Decorative brackets and supports.

Discouraged:

- Bright multi-colored awnings.
- Storefront awnings more than 5 feet above the street front windows.
- Back-lit awnings.



Ninth St. at Bay Village



Bay Ave. at Pearl St.



# 7. Streetscape

Over time improvements can be made to the character and quality of the commercial district at a larger scale than individual properties, by envisioning an improved streetscape throughout the district. Not all properties can change or contribute, but improvements may be made in terms of building positioning on lots, parking layout, sidewalk design, landscaping, coordination of street furnishings and details, lighting, and improved quality of signage. These are all in addition to the character and quality of buildings addressed in other sections of these guidelines. The goals for this include making the downtown more pedestrian friendly, more attractive, and more lively along the street edge, while keeping it more quiet and better buffered on the neighborhood sides.

This all needs to be also coordinated with access for fire safety, utility easements, County Road conditions and regulations, storm water management, flood resilience, and other more technical aspects of development.

The single largest factor in defining the streetscape is the position of buildings in relation to the street, sidewalks, and parking areas. We encourage the provision of wide sidewalks and street side plazas, the inclusion of porches, and most parking on the side or rear of buildings. In the case of buildings with parking beneath we encourage the screening of that parking and provision of landscaped pedestrian walks at ground level along the street.

## Encouraged

- Buildings located on corners close to the setback, especially at intersections.
- In long continuous buildings use building massing, bays, porches, recesses, and dormers to break up the straight lines.
- Clearly defined and safe pedestrian ways through parking lots, that connect to sidewalks.
- Landscaped parking lots.
- If parking is under a raised building provide screening and landscaping on the boulevard. side and any side streets.
- Locate dumpsters on the sides and rear of properties, in well screened areas- but as far away from the neighboring homes as possible. Share facilities for neighboring small lots.
- Coordination of neighboring properties for sidewalks, walkways, and building locations.



Bay Ave. at Fourth St. looking north

# 8. Landscaping

## Indigenous and Native Plants

### Flowering Perennials

- Blazing star (*Liatris spicata*)
- Butterfly milkweed (*Asclepias spp.*)
- Spotted bee balm (*Monarda punctata*)
- Wild bergamot (*Monarda fistulosa*)
- Scarlet bee balm (*Monarda didyma*)
- Summersweet (*Clethra alnifolia*)
- New Jersey tea (*Ceanothus americanus*)
- Black-Eyed Susan (*Rudbeckia spp.*)
- Asters (*Aster spp.*)

### Shrubs and Trees

- Wild or smooth hydrangea (*Hydrangea arborescens*)
- Inkberry holly (*Ilex glabra*)
- Bayberry (*Myrica pensylvanica*)
- Winterberry (*Ilex glabra*)
- Common ninebark (*Physocarpus opulifolius*)
- Crape Myrtle (*Lagerstroemia indica*)

Vegetation, including trees, shrubs, ground cover, and seasonal plantings can contribute greatly to the character of the business district. Properly selected, designed, and maintained landscaping can serve to improve the character and attractiveness of the downtown strip. All plantings in this area need to be wind and salt tolerant, as they are subject to fairly regular harsh conditions.

Landscape areas can also double as pervious areas to assist in the absorption of rainwater to the ground, and lessening runoff into streets and neighboring properties.

#### Encouraged:

- The creation of seasonal planter beds for colorful annuals
- The designation of pervious green strips around all properties, to assist in the reduction of stormwater flows off site. The exceptions to this are for side street back out parking areas, shared access in side yards, and driveway access lanes from the road.
- Buffer plantings in the rear setbacks between commercial and residential uses including a dense planting of conifers to about 10' high and small deciduous trees to about 20' high every 30'
- Medium to large street shade or flowering trees every 30' at parking areas and along buildings that have parking underneath with no commercial store frontage.
- Low shrubs, flowering perennials, and spreading ground covers in the landscape beds that surround and break up parking areas.

#### Discouraged:

- Planting on or near corners that obstruct views for safe traffic turning, entry onto roads, and pedestrian crossing
- Tall trees in front of buildings and signs that obscure commercial visibility
- Seasonal plantings of non native trees, palms, etc.

# 9. Flood Elevation

With a long history of significant storms in the area, and a predicted sea level rise (which is likely to exacerbate their effects over the next 50 – 100 years), structures must be built to meet or exceed FEMA and town requirements.

Adhering to FEMA requirements and creating an attractive and lively street environment are challenging in the town as the street elevation is significantly below required flood elevation.

Property owners and design professionals are advised to closely review flood elevation conditions and requirements with the building inspector prior to design improvements. Building renovations are also subject to FEMA requirements per code. Due to this situation, flexible and innovative designs shall be considered.

Mostly there are four conditions that are encountered.

1. Renovation of existing buildings with moderate improvements. As long as they stay below the threshold of “substantial improvements” These may remain as is but are advised to make efforts to improve flood protection.
2. Renovation of existing buildings that is more involved. These need to be floodproofed, which requires structural review to ensure that the existing structure can or will be improved to resist the loads imposed.
3. New buildings that need to have the floor raised to freeboard requirements. This is generally about 6 to 7’ above the sidewalk, so they present quite a challenge to accessibility and pedestrian friendly environment
4. New buildings that are partly raised and partly flood protected. Current experience shows that floodproofing is more reasonably achieved to a depth of about 3’. This would imply a good model would be buildings with the floor raised about 3’ above the street, and then floodproofed another 3’ or 4’ to freeboard level.

Encouraged:

- Floodproofing of existing buildings that are being renovated, according to FEMA standards and good practice if and as possible.
- In new and raised buildings consideration to provide good connections to the street, and incorporate accessibility in ways that does not separate businesses from the pedestrian way (see #11 Accessibility)

# 10. Accessibility

People with accessibility needs, whether temporary or permanent, enjoy both public and private places. It is required that towns provide access that meets the requirements set forth in the American with Disabilities Act and the State of New Jersey codes.

In providing accessibility, ramps should be built to minimize obstructions of the sidewalk to porches and entrances. This is best achieved by providing ramps perpendicular to the sidewalks. These ramps may serve multiple tenants with shared porches or arcades.

- Ramps are permitted in side yard setbacks

Encouraged:

- The development of shared access, no more than 100 feet apart, including shared access even if on neighboring lots.
- It is preferable to place access ramps on the side of buildings rather than across the front.
- All ramps on the side of buildings should provide a clearly visible entry from street or public way and lead to the main entrance.

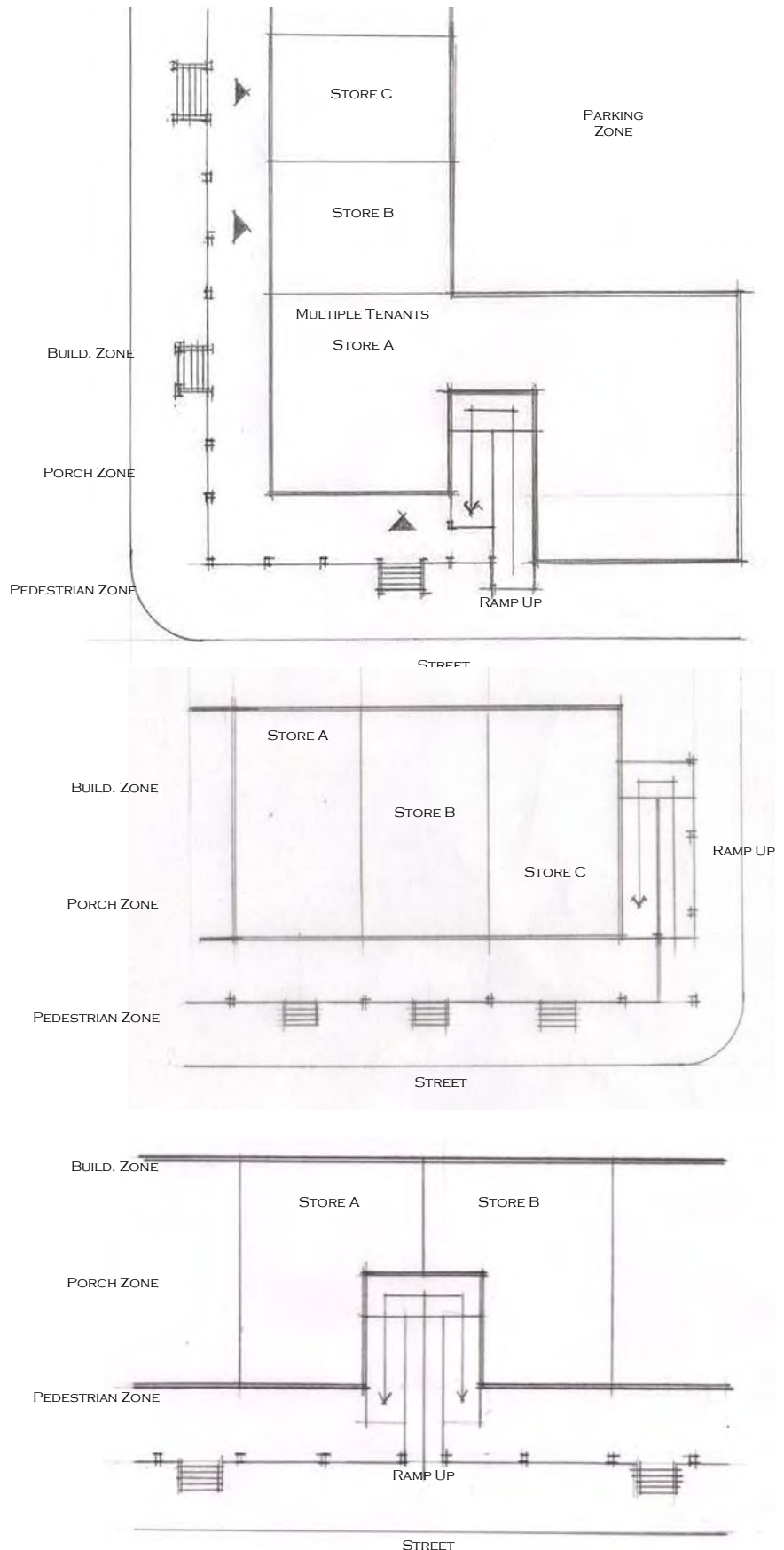

# 11. Parking

See Beach Haven Zoning Code for on-site parking regulations.

- Parking space 9'x18'

Encouraged:

- Parking to the extent possible on the side and rear of lots, with building facades as near as possible to Bay Blvd.
- Landscaped parking lots (heads of space 2.5' landscape strip with low shrubs and some trees between spaces.
- All parking under buildings well screened from public view
- Min. 23' aisle width for parking lot circulation.
- Provide bike parking areas with racks sufficient for 1/4 of the expected customers in any particular business. This should not be on the sidewalk or in a public way.

Discouraged:

- Parking lots on street corners
- Double loaded parking lots along the highway

Allowed:

- Parking to back up into alleys
- Stacked parking for employee spaces



Second St. at Bay Ave. looking south

# 12. Lighting



Second St. at Bay Ave.



308 Centre St.

The design of exterior lighting fixtures shall enhance and complement the character of a specific building or space, and must reflect the traditional element of downtown. Exterior lighting shall serve as a security measure and will also increase general visibility.

## Required:

- The lighting of buildings, landscaping, driveways and signs, as well as other exterior objects, shall be designed to minimize the light and glare on adjacent neighbors per town Zoning Code and Master Plan

## Encouraged:

- Gooseneck lighting and externally illuminated signs are encouraged.
- Pole-mounted fixtures in vehicular use areas should not exceed a mounting height of 14 feet, and such poles should be located so as not to be a hazard in a pedestrian path.
- Pole-mounted fixtures in pedestrian use areas should not exceed a mounting height of 12 feet, and such poles should be located so as not to be a hazard in a pedestrian path.
- Wall-mounted lighting fixtures should not exceed the height of the main structure, and should be provided in a manner that will minimize glare to vehicular and pedestrian traffic.
- All outdoor lighting should provide illumination at ground level not to exceed the range set below:

### Commercial Areas:

- Average Illumination: 1.5 Foot Candles
- Maximum Illumination: 5.0 Foot Candles
- In addition, outdoor lighting should be designed so that any overspill of lighting onto adjacent properties should not exceed one-half foot candle vertical and one-half foot candle horizontal illumination to the adjacent properties or structures.
- Outdoor lighting poles and fixtures should conform in character and style to the district.

## Discouraged:

- The use of up-lighting should be avoided to minimize light pollution of the night sky and to prevent light trespassing onto adjacent properties.

# 13. Fencing & Screening

## Fencing

Fences can be an attractive ways of separating the public and private sector realms. They are a special detail to be included in the traditional style of development for the area. Fencing, garden walls, or hedges are strongly encouraged, and may be constructed along all unbuilt rights-of-way that abut streets and alleys.

Encouraged:

- Per Zoning Code, provide 8' high fence at the rear of commercial property adjacent to residential zone. Sideyard fences may be installed up to 5' high solid with 1' lattice on top. Front yard fences and side yard to the line of the building are limited to 4' high.
- Made of wood, metal, concrete or synthetic material as approved by the town.
- Concrete posts and garden walls are allowed. Continuous concrete walls should be textured or patterned .

Prohibited:

- Chain link fencing
- Barbed and razor wire fencing
- Raw CMU block fences and walls

## Screening

Screening is a valuable tool to hide items that generally are not attractive, including but not limited to HVAC equipment, trash collection areas, service, storage and parking areas.

Required:

- All solid waste collection areas for dumpsters or totes are to be screened on three sides.

Encouraged:

- HVAC units to be roof top units (RTU), to be located 25' from rear property line and to be screened.
- RTU required to be low sone level or have acoustic screening.
- HVAC RTU located at center of roof where possible.
- Screening should be made of wood, synthetic material, or masonry (decorative block, brick, or stone).
- Landscaping in front of other screening material.
- Combine visual with acoustic screening where possible.

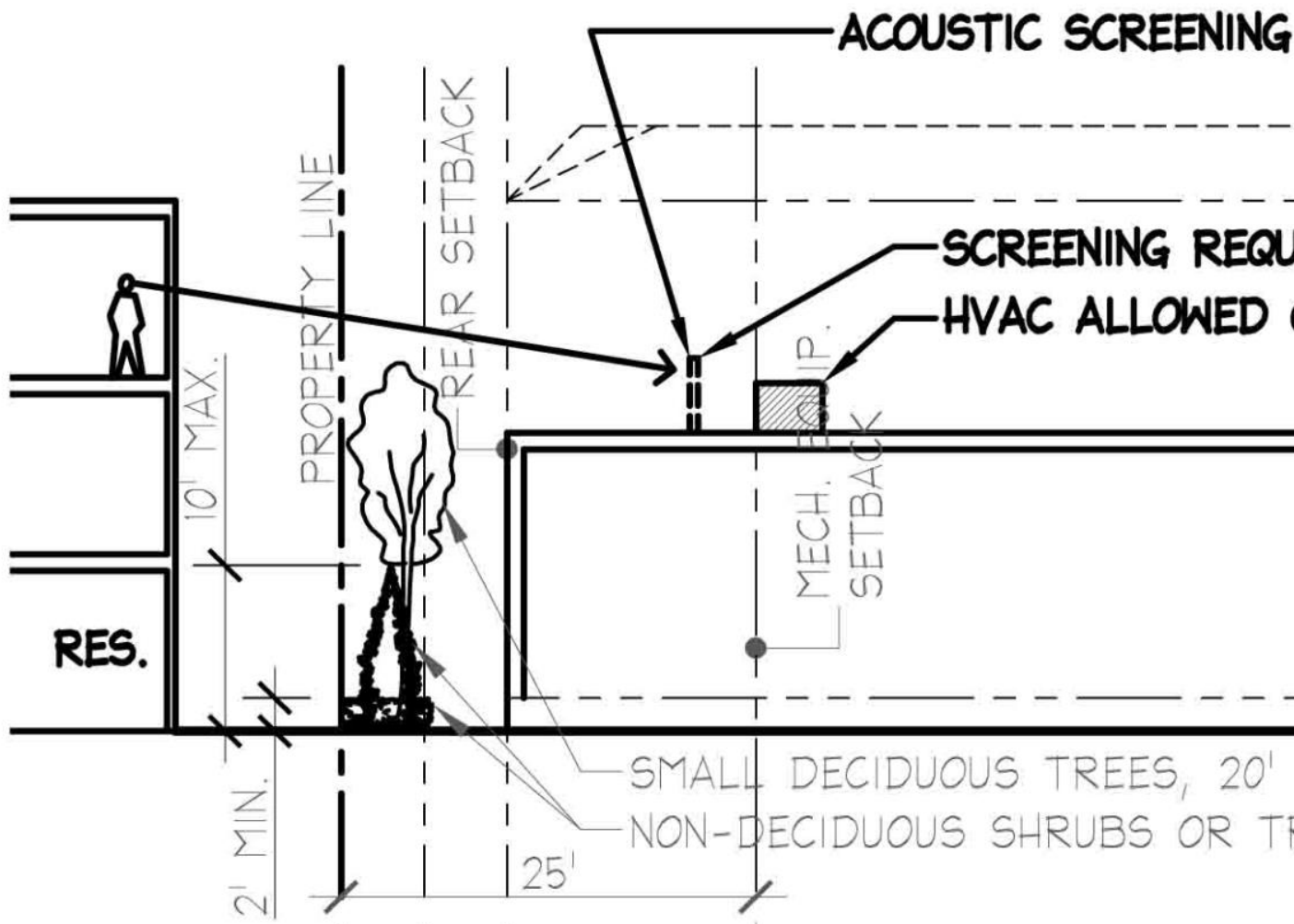



**SLOPING PARAPETS ALLOWED  
(6/12 MIN. & 12/12 MAX. ROOF PITCH)**

**MAY BE REQUIRED BY NOISE ORDINANCE**

BUILDING HEIGHT LIMIT

**REQUIRED  
ON ROOF, MUST BE SCREENED FROM VIEW**

MAX. @ 30'-0" O.C.  
TREES

FREEBOARD OF 18"-24" ABOVE  
BASE FLOOD ELEVATION (BFE)

2'  
LANE

ACOUSTIC SCREENING MAY BE REQUIRED

SCREENING

HVAC ALLOWED ON ROOF, MUST BE SCREENED

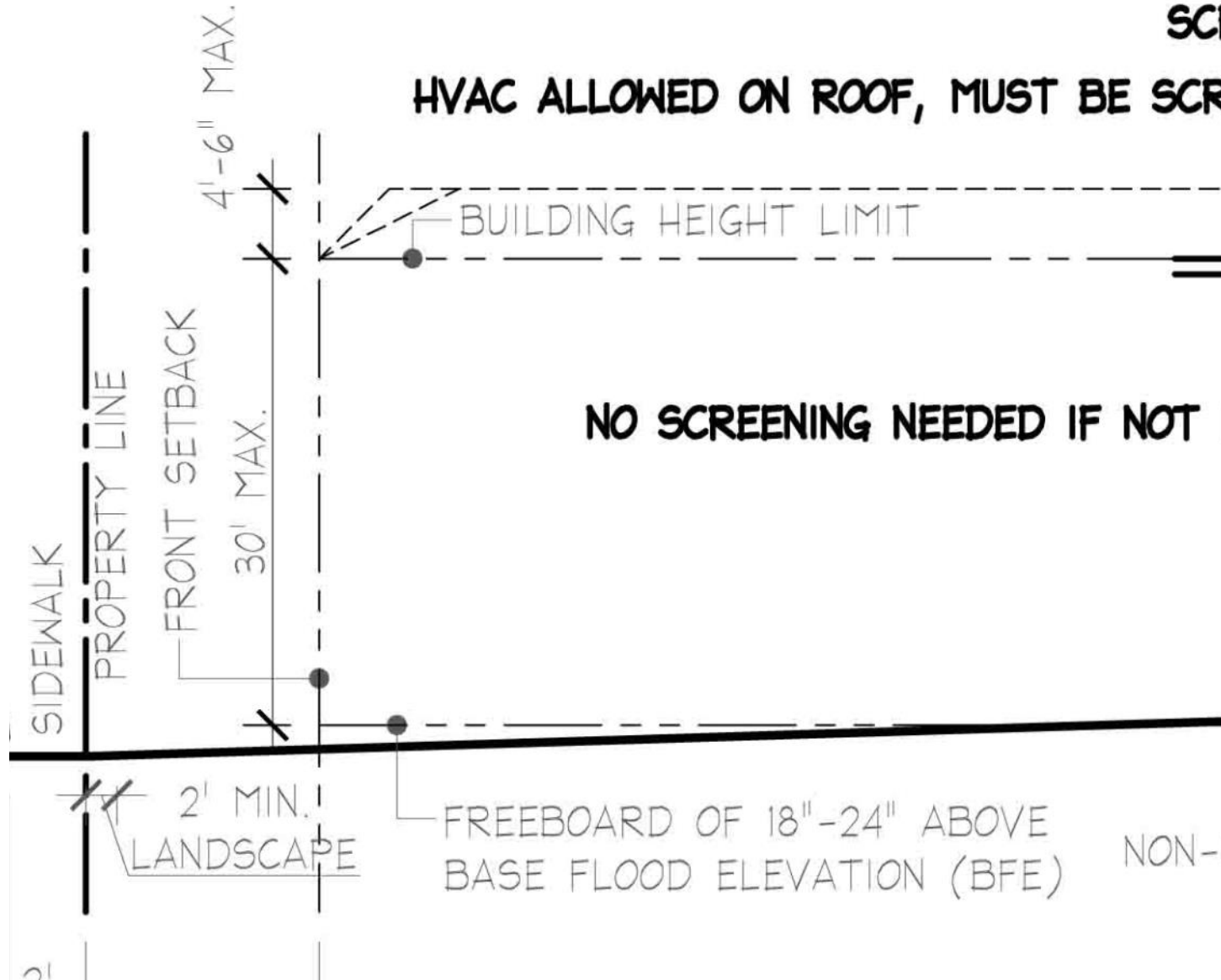

REQUIRED BY NOISE ORDINANCE

SCREENING REQUIRED

SCREENED FROM VIEW

IN VIEW

MECH. EQUIP.  
SETBACK

REAR SETBACK

PROPERTY LINE

10' MAX.

RES.

SMALL DECIDUOUS TREES  
20' MAX. @ 30'-0" O.C.

DECIDUOUS SHRUBS OR TREES

2' MIN.

5'

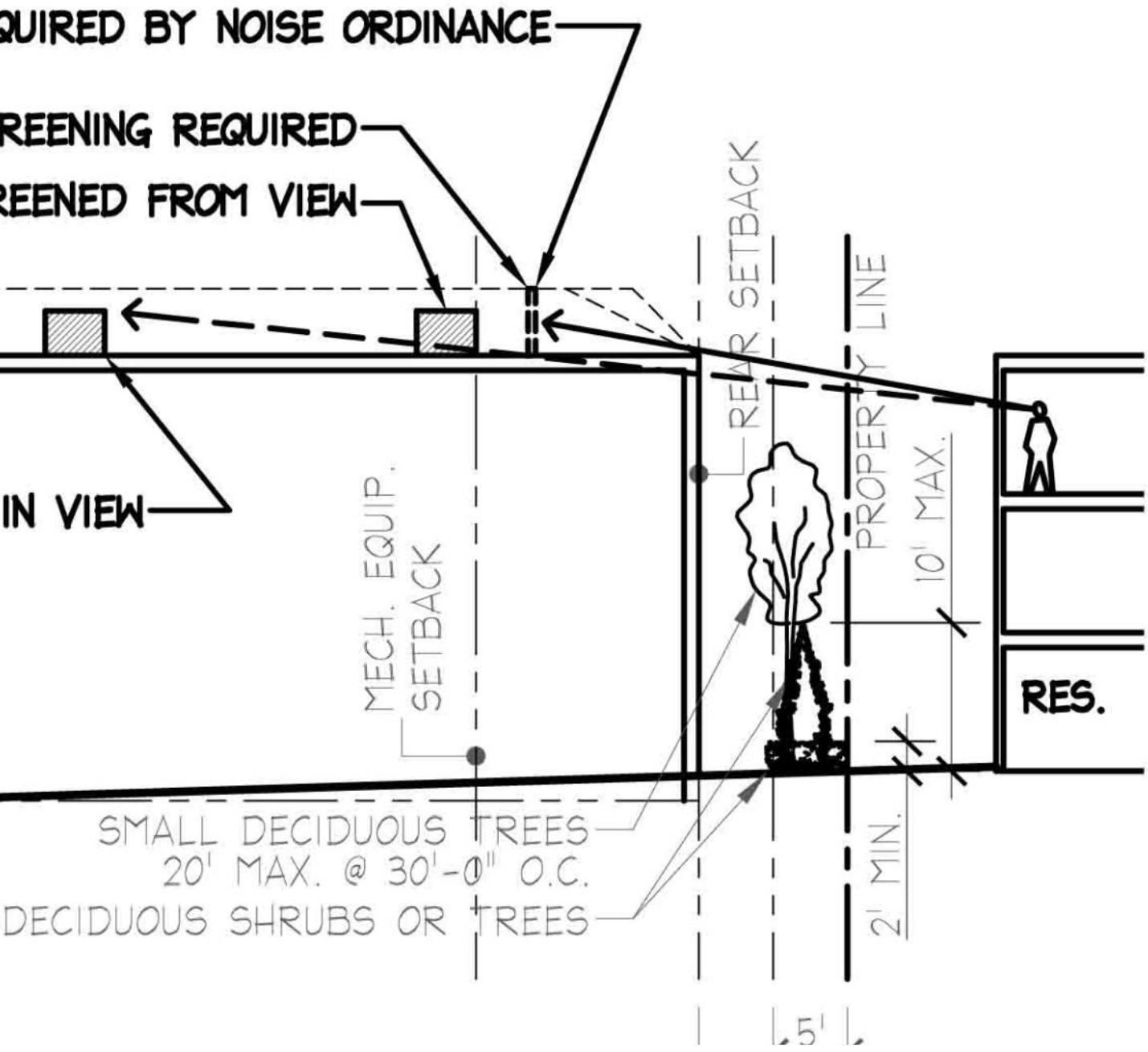

# 14. Service & Loading

## Required:

- Loading zones shall be provided off street according to the current zoning code requirements.
- Service alleys are to remain open and unencumbered for delivery and emergency access.

## Encouraged:

- The service side of buildings shall continue in ways the detail and quality of the front and sides. This includes the provision of some windows, and the continuity of siding, roofing, and trim.
- Dumpsters and totes are encouraged to be on a concrete pad with fence screening on 3 sides.
- Enhanced buffers to residential and historic districts with additional fencing, planting, and separation.
- Lighting designed a well shielded downlighting with no significant light trespass to neighboring residences.

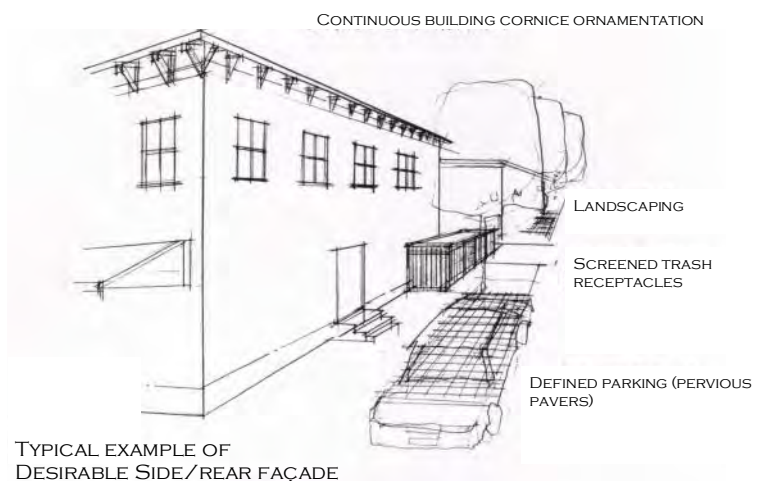
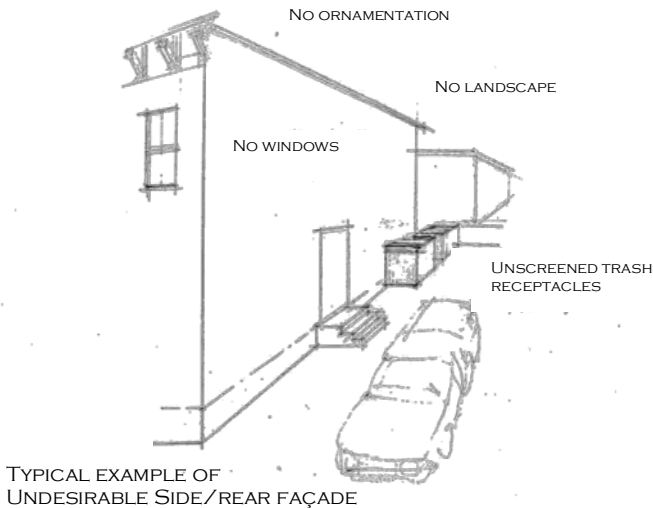

# 15. Signage

Signs are important and useful tools in a community. Signage shall be regulated and reviewed on a case by case basis according to size/height, location, shape, lettering, illumination, mounting attachment method, color and materials.

Required:

- Provide allowed signage as per town zoning code.

Encouraged:

- High Quality signage
- Signs with borders
- Externally lit signs with carved or raised letters

Allowed:

- High quality awnings with signage
- High quality and special signs within uncluttered storefront windows

Discouraged:

- Large plastic faced pylon signs
- Flashing lights
- Sign clutter in windows
- Inflatables
- Signage and flags on sidewalks



220 Centre St.



Ninth St. at Bay Ave.



116 N West Ave. at Dock Rd.



Eleventh St. at Bay Ave.



Ninth St. at Bay Ave.